



UNIVERSITY OF CAMBRIDGE INTERNATIONAL EXAMINATIONS
General Certificate of Education Ordinary Level

COMBINED SCIENCE

5129/12

Paper 1 Multiple Choice

October/November 2013

1 hour

Additional Materials: Multiple Choice Answer Sheet
Soft clean eraser
Soft pencil (type B or HB is recommended)



READ THESE INSTRUCTIONS FIRST

Write in soft pencil.

Do not use staples, paper clips, highlighters, glue or correction fluid.

Write your name, Centre number and candidate number on the Answer Sheet in the spaces provided unless this has been done for you.

DO NOT WRITE IN ANY BARCODES.

There are **forty** questions on this paper. Answer **all** questions. For each question there are four possible answers **A, B, C** and **D**.

Choose the **one** you consider correct and record your choice in **soft pencil** on the separate Answer Sheet.

Read the instructions on the Answer Sheet very carefully.

Each correct answer will score one mark. A mark will not be deducted for a wrong answer.

Any rough working should be done in this booklet.

A copy of the Periodic Table is printed on page 20.

Electronic calculators may be used.

This document consists of **18** printed pages and **2** blank pages.



1 The diagram shows a plant cell as seen under a microscope.

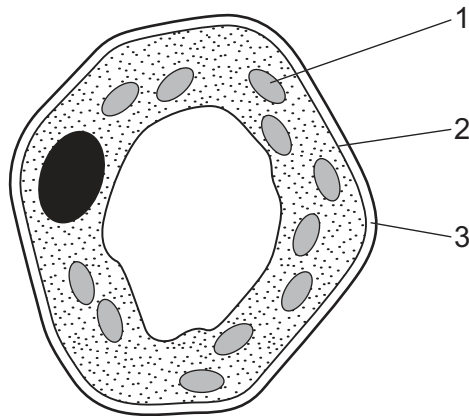

Which of the numbered parts carry out these functions?

	controlling entry of dissolved substances	formation of carbohydrates
A	1	3
B	2	1
C	3	2
D	3	1

2 The diagram represents how some red blood cells change when they are placed in solution X.

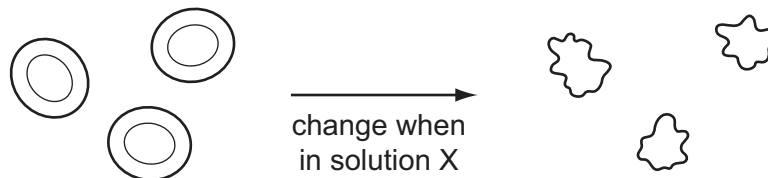

What describes the water concentration in solution X and in which direction does water move?

	water concentration in solution X	direction of water movement
A	higher than in cells	into the cells
B	higher than in cells	out of the cells
C	lower than in cells	into the cells
D	lower than in cells	out of the cells

- 3 In an experiment to investigate germinating barley grains, two petri dishes are set up as shown in diagram 1 and left for three days.

Iodine solution is then added to the starch-agar gel. The results are shown in diagram 2. The shaded areas indicate the presence of starch.

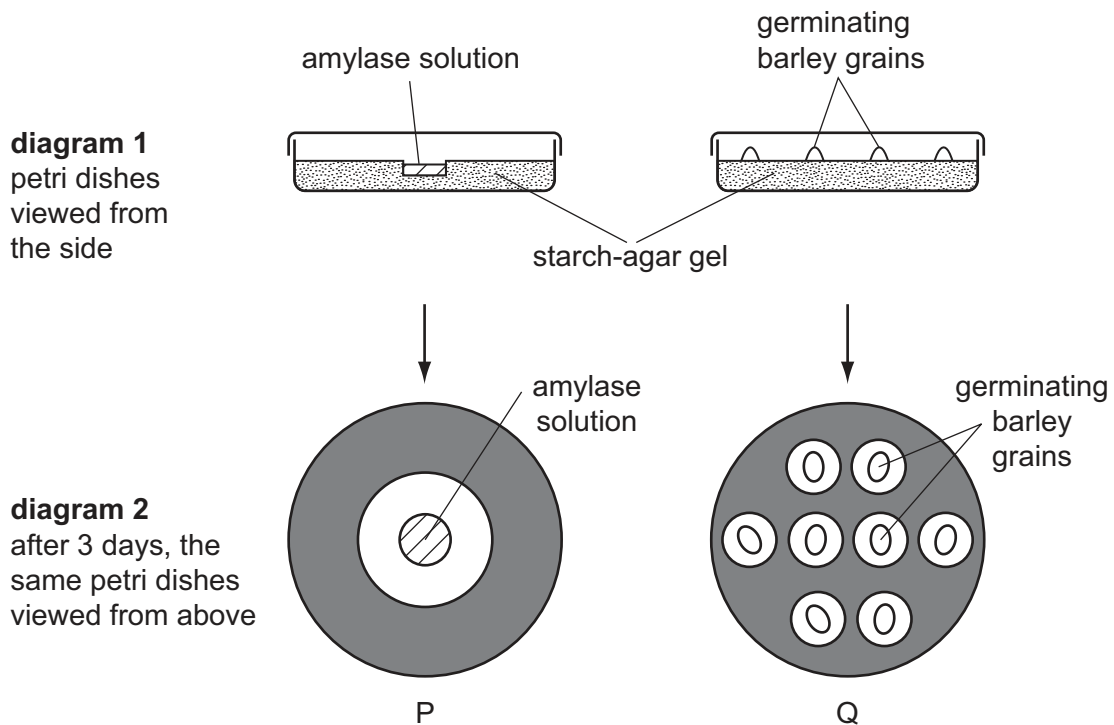

What is shown by dishes P and Q?

	dish P	dish Q
A	amylase digests starch	germinating barley grains digest starch
B	amylase digests starch	germinating barley grains do not digest starch
C	barley grains produce amylase	germinating barley grains digest starch
D	barley grains produce amylase	germinating barley grains do not digest starch

- 4 What is caused by the lack of nitrate ions in plant leaves?

- A** all leaves very dark green
- B** leaves yellow between the veins
- C** pale leaves with poor growth
- D** wilting of the leaves

5 The diagram represents the liver and associated blood vessels.

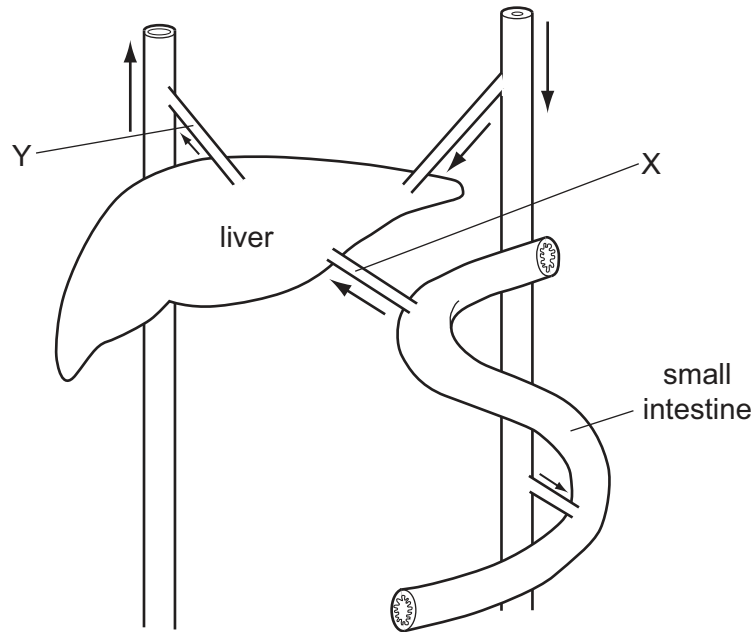

After a meal, how do the levels of glucose and urea in the blood change as the blood passes from X to Y?

	glucose	urea
A	decrease	decrease
B	decrease	increase
C	increase	decrease
D	increase	increase

6 The diagram shows a vertical section through the heart.

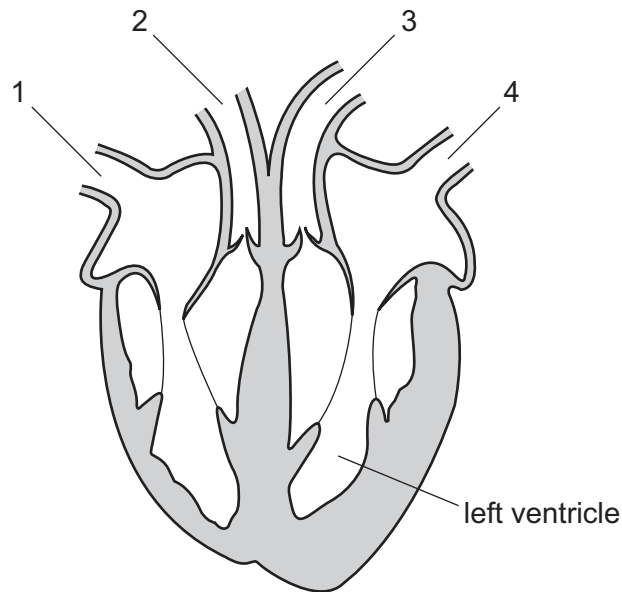

Which numbered blood vessels carry out these functions?

	carries blood to lungs	carries blood from body
A	1	4
B	2	1
C	3	2
D	4	3

7 What is the approximate oxygen content of expired air?

- A** 0% **B** 16% **C** 20% **D** 79%

8 Which diagram shows how light from a near object is focused on the retina to form a clear image?

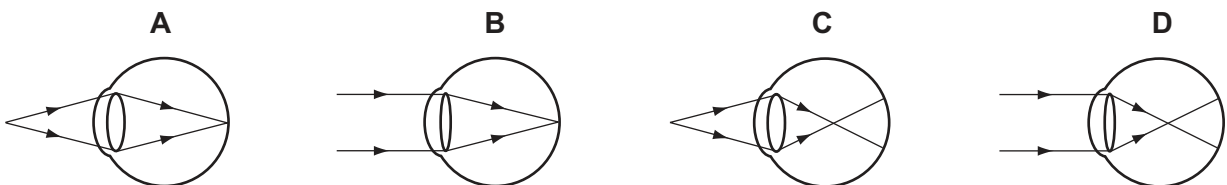

9 What are the effects of alcohol and heroin on the body?

	alcohol	heroin
A	depressant	depressant
B	depressant	stimulant
C	stimulant	depressant
D	stimulant	stimulant

10 Which statement is **not** correct?

- A** A producer can have more than one consumer.
- B** Energy flowing through biological systems is recycled.
- C** Food chains show energy flow in ecosystems.
- D** The Sun is the principal source of energy input into biological systems.

11 Which human activity has caused most damage to tropical rain forests?

- A** burning fossil fuels
- B** flooding of land
- C** logging for timber
- D** searching for medicinal plants

12 After sexual intercourse, sperm can survive for 3 days in the uterus and oviducts. Ovulation can occur any time from day 13 to day 15 and an egg cell can live for 2 days after ovulation.

Which is the best estimate of the length of the fertile phase of the menstrual cycle?

- A** 2 days **B** 3 days **C** 5 days **D** 7 days

13 What are symptoms of syphilis?

- A** cough up blood, pain when breathing, fatigue
- B** pain when urinating, yellow or green discharge from the penis, swollen testicles
- C** rash, ulcers, blindness, paralysis, mental confusion
- D** tremors, clumsiness, memory loss, mood changes

14 A gas X is insoluble in water and less dense than air.

An impure supply of X contains water vapour and a water-soluble impurity.

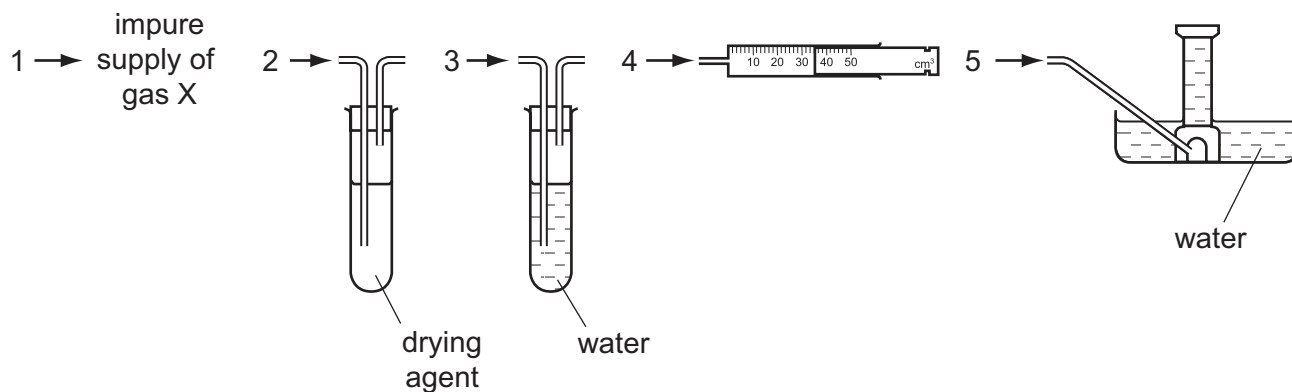

In which order should pieces of apparatus be joined together to collect a pure, dry sample of X?

- A** 1, 2, 3, 4 **B** 1, 2, 3, 5 **C** 1, 3, 2, 5 **D** 1, 3, 2, 4

15 The symbol for an atom of potassium is ${}_{19}^{39}\text{K}$.

What does the number 39 represent for an atom of potassium?

- A** its position in the Periodic Table
B the number of electrons plus protons plus neutrons
C the number of nucleons
D the number of protons

16 Which diagram shows the electron arrangement in calcium fluoride?

Only the outer shell electrons are shown.

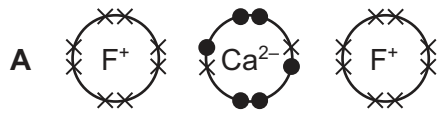

key

● = electrons from calcium

× = electrons from fluorine

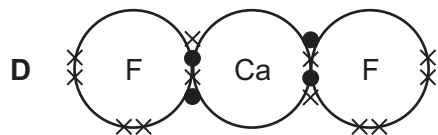
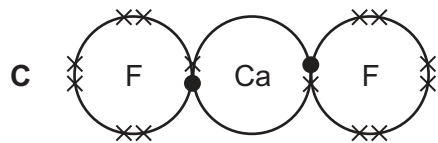
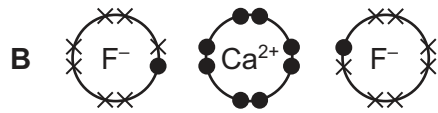

17 A molecule of carbon disulfide, CS₂, contains one carbon atom covalently bonded to two sulfur atoms.

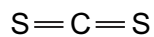

How many electrons make up all of the covalent bonds in one molecule of CS₂?

A 2

B 4

C 6

D 8

18 In the Haber process, nitrogen reacts with hydrogen to form ammonia.

What is the balanced equation for this process?

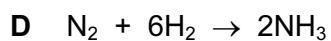
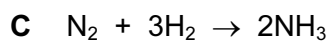
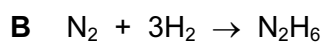
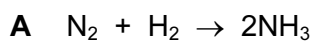

19 A man suffering from an excess of acid in his stomach has no indigestion tablets.

Which substance could he take to neutralise this acidity?

- A aspirin (pH 6 in solution)
- B bicarbonate of soda (pH 8 in solution)
- C lemon juice (pH 5)
- D salt water (pH 7)

20 In 2011, the existence of the element with atomic number 114 was confirmed.

This element is placed directly under lead in the Periodic Table.

Which row describes this element?

	number of outer electrons	metal or non-metal
A	4	non-metal
B	4	metal
C	7	non-metal
D	7	metal

21 Copper is a typical metal.

What is **not** a property of copper?

- A ductile (can be drawn into wires)
- B good conductor of heat
- C high melting point
- D poor conductor of electricity

22 Metal X reacts with the oxide of metal Y but not with the oxide of metal Z.

What is the order of reactivity of the metals X, Y and Z?

	most reactive \longrightarrow least reactive		
A	X	Z	Y
B	Y	X	Z
C	Z	X	Y
D	Z	Y	X

23 The diagram shows apparatus used to investigate the rusting of iron.

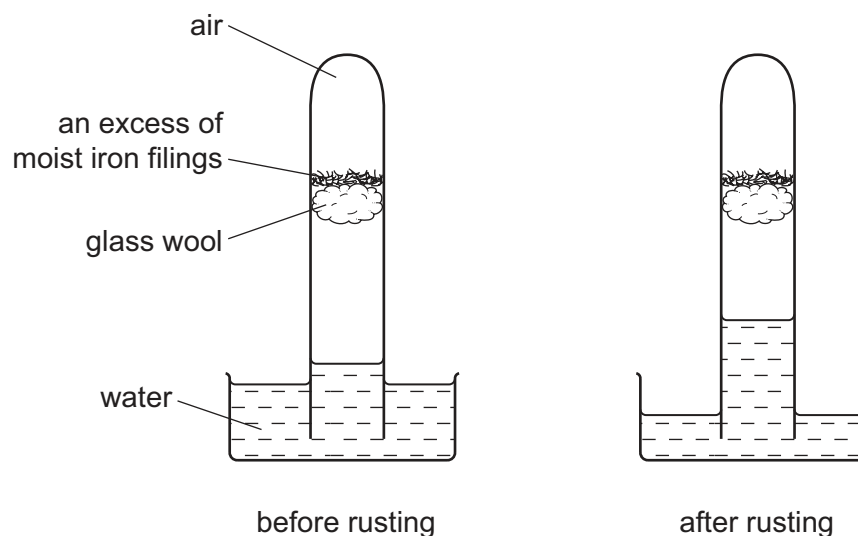

Which statement is correct?

- A The amount of gas remaining is 79% of the original volume.
 - B The iron acts as a catalyst in this experiment.
 - C The iron only reacts with the nitrogen in the air.
 - D The volume of gas remaining is about one fifth of the original volume.
- 24 Which compound will **not** produce ammonia when heated with ammonium sulfate?
- A calcium oxide
 - B magnesium oxide
 - C sodium hydroxide
 - D sulfuric acid
- 25 Which statement about a homologous series is correct?
- A The boiling point increases with decreasing relative molecular mass.
 - B The members have the same chemical formula.
 - C The members have similar chemical properties.
 - D The relative molecular masses of consecutive members differ by 12.

26 Which compound undergoes an addition reaction with bromine?

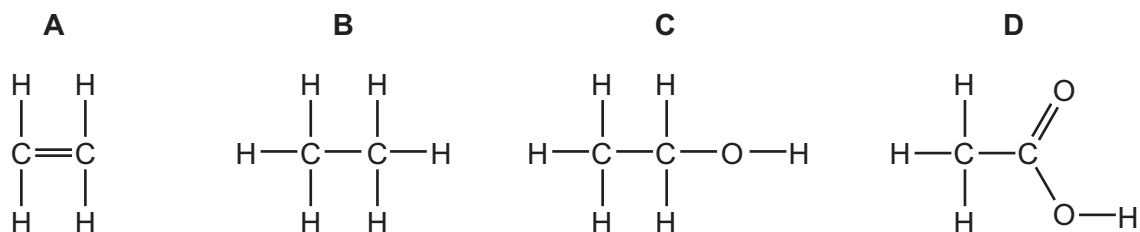

27 The diagram shows four stages in a reaction scheme.

Which stage involves an addition reaction?

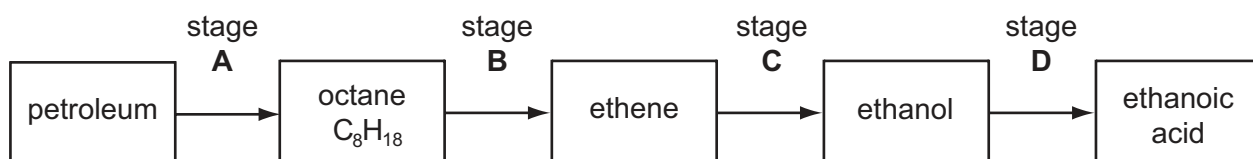

28 The graph shows the speed of a car over the first ten seconds of a journey.

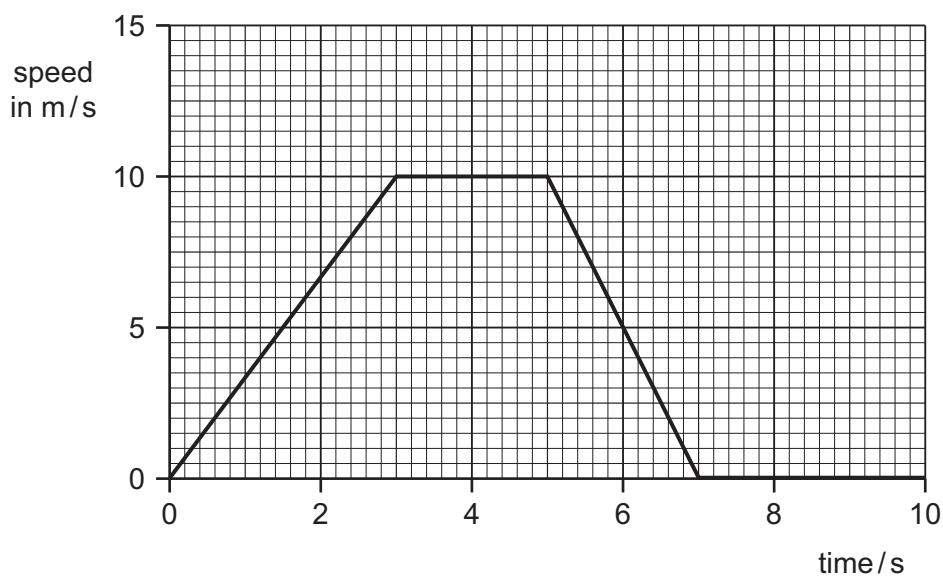

Which statement about the acceleration of the car between 3 s and 5 s is true?

- A** The acceleration decreases.
- B** The acceleration increases.
- C** The acceleration is zero.
- D** The acceleration is 10 m/s.

- 29 Two liquids form separate layers in a measuring cylinder. The two liquids cannot be mixed. The upper liquid has a density of 0.8 g/cm^3 and the lower liquid has a density of 1.0 g/cm^3 .

A cube of material has a mass of 20 g. The length of each side of the cube is 2 cm. The cube is carefully lowered into the measuring cylinder.

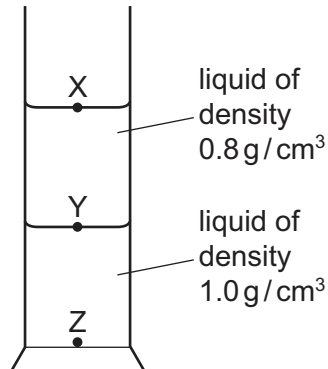

What is the density of the cube material and the final position of the cube in the measuring cylinder?

	density g/cm^3	final position
A	0.4	X
B	0.4	Y
C	2.5	Y
D	2.5	Z

- 30 If a nut and bolt are difficult to undo, it may be easier to turn the nut by using a longer spanner.

This is because the longer spanner gives

- A** a larger turning moment.
- B** a smaller turning moment.
- C** less friction.
- D** more friction.

31 The extension-load graph is for a spring.

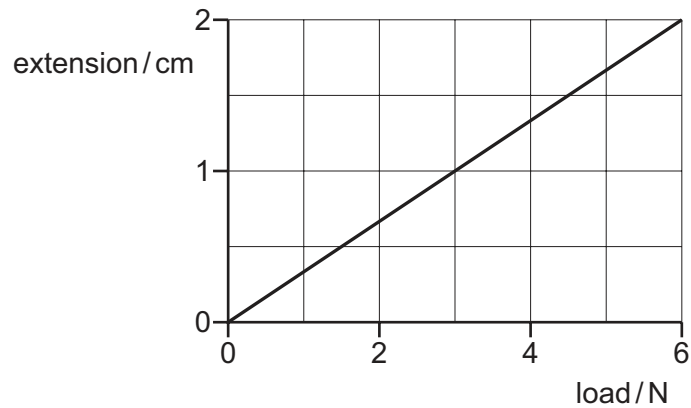

The original length of the spring was 10 cm.

Which load would give a spring length of 15 cm?

- A** 5 N **B** 15 N **C** 30 N **D** 45 N

32 The diagram shows a coloured crystal being heated in a beaker of water. The crystal dissolves and the coloured water circulates around the beaker.

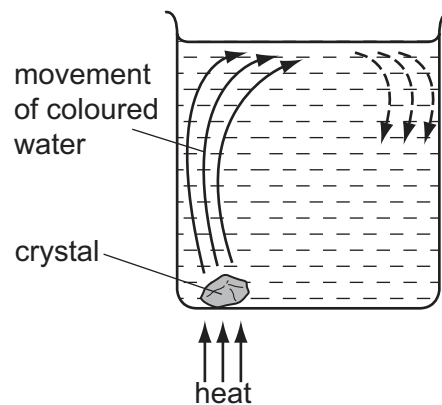

What is happening to cause the water above the crystal to rise?

- A** The water contracts and its density decreases.
B The water contracts and its density increases.
C The water expands and its density decreases.
D The water expands and its density increases.

33 A ray of light travels from air into glass. The refractive index of the glass is 1.5.

Which of the following pairs of angles are correct?

	angle of incidence	angle of refraction
A	21.5°	20.0°
B	40.0°	30.0°
C	60.0°	35.3°
D	80.0°	53.3°

34 The diagram shows a positively charged acetate strip and a negatively charged polythene strip that are freely suspended.

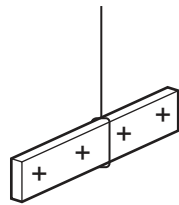

acetate strip

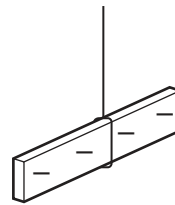

polythene strip

Two rods X and Y are brought up in turn to these two strips.

Rod X attracts the acetate strip but repels the polythene strip.

Rod Y does not repel either the acetate strip or the polythene strip.

Which type of charge is on each rod?

	rod X	rod Y
A	negative	positive
B	negative	uncharged
C	positive	negative
D	positive	uncharged

- 35 A series circuit consists of a battery, an ammeter, a lamp and a resistor. A voltmeter is placed across the lamp and the resistor.

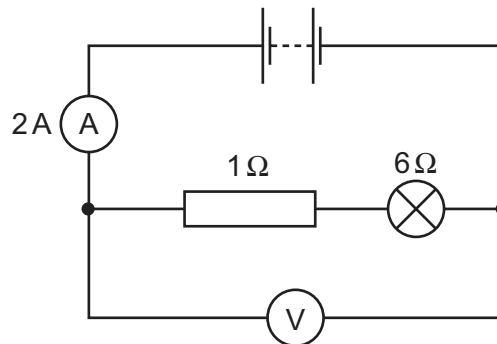

What is the voltmeter reading?

- A** 2V **B** 10V **C** 12V **D** 14V
- 36 A small heater operates at 12V, 2A.
How much energy is used in 5 minutes?
- A** 30J **B** 120J **C** 1800J **D** 7200J
- 37 What is an example of induced magnetism?
- A** a compass needle pointing north
B a north pole attracting iron filings
C a north pole repelling a north pole
D a negatively charged balloon attracting small pieces of paper

38 Which transformer arrangement produces an output voltage that is larger than the input voltage?

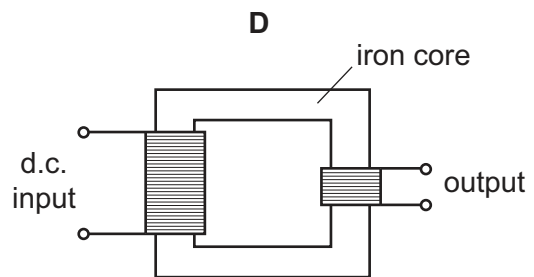
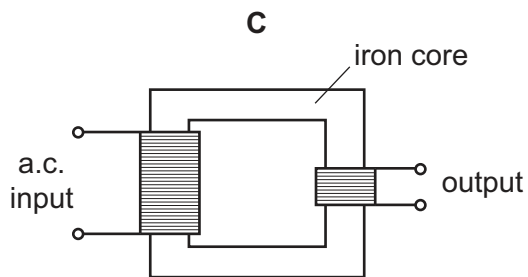
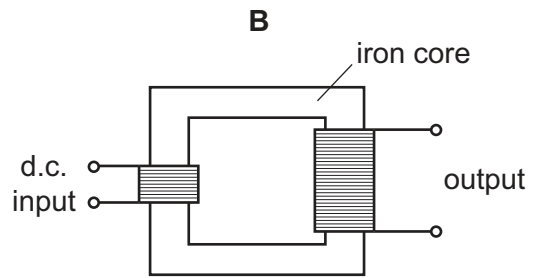
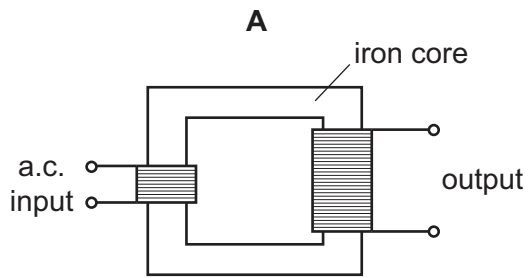

39 A nucleus of the element cobalt may be represented by the symbol ${}_{27}^{59}\text{Co}$.

What is the structure of this nucleus?

	number of protons	number of neutrons
A	27	32
B	27	59
C	59	27
D	59	32

40 In an experiment to find the half-life of a radioactive nuclide, the following results were obtained.

activity / counts per min	4100	2800	1900	1300	900	600
time / min	0	2	4	6	8	10

What is the **approximate** half-life of the nuclide?

- A** 2 min **B** 4 min **C** 6 min **D** 8 min

DATA SHEET
The Periodic Table of the Elements

		Group													
		I	II	III	IV	V	VI	VII	VIII	IX	X				
		1 H Hydrogen 1										4 He Helium 2			
7 Li Lithium 3	9 Be Beryllium 4											19 F Fluorine 9			
23 Na Sodium 11	24 Mg Magnesium 12	27 Al Aluminium 13	28 Si Silicon 14	31 P Phosphorus 15	32 S Sulfur 16	35.5 Cl Chlorine 17	36 Ar Argon 18						20 Ne Neon 10		
39 K Potassium 19	40 Ca Calcium 20	51 V Vanadium 23	52 Cr Chromium 24	55 Mn Manganese 25	56 Fe Iron 26	59 Co Cobalt 27	59 Ni Nickel 28	64 Cu Copper 29	65 Zn Zinc 30	70 Ga Gallium 31	73 Ge Germanium 32	75 As Arsenic 33	79 Se Selenium 34	80 Br Bromine 35	84 Kr Krypton 36
85 Rb Rubidium 37	88 Sr Strontium 38	91 Zr Zirconium 40	96 Mo Molybdenum 42	101 Ru Ruthenium 44	106 Pd Palladium 46	108 Ag Silver 47	112 Cd Cadmium 48	115 In Indium 49	119 Sn Tin 50	122 Sb Antimony 51	128 Te Tellurium 52	127 I Iodine 53	131 Xe Xenon 54		
133 Cs Caesium 55	137 Ba Barium 56	181 Ta Tantalum 73	184 W Tungsten 74	190 Os Osmium 76	195 Pt Platinum 78	197 Au Gold 79	201 Hg Mercury 80	204 Tl Thallium 81	207 Pb Lead 82	209 Bi Bismuth 83	210 Po Polonium 84	210 At Astatine 85	210 Rn Radon 86		
226 Ra Radium 88	227 Ac Actinium 89											227 Fr Francium 87			
													169 Tm Thulium 69	173 Yb Ytterbium 70	175 Lu Lutetium 71
													167 Er Erbium 68	168 Md Mendelevium 101	102 No Nobelium 102
													162 Dy Dysprosium 66	165 Ho Holmium 67	169 Es Einsteinium 99
													159 Tb Terbium 65	162 Cf Californium 98	103 Lr Lawrencium 103
													157 Gd Gadolinium 64	162 Bk Berkelium 97	
													152 Eu Europium 63	162 Am Americium 95	
													150 Sm Samarium 62	162 Pu Plutonium 94	
													144 Nd Neodymium 60	162 Np Neptunium 93	
													141 Pr Praseodymium 59	162 Pa Protactinium 91	
													140 Ce Cerium 58	162 Th Thorium 90	
													232 Th Thorium 90	238 U Uranium 92	
													232 Th Thorium 90	238 U Uranium 92	

*58-71 Lanthanoid series
†90-103 Actinoid series

a = relative atomic mass

X = atomic symbol

b = proton (atomic) number

Key

a	X	b	†

The volume of one mole of any gas is 24 dm³ at room temperature and pressure (r.t.p.).

Permission to reproduce items where third-party owned material protected by copyright is included has been sought and cleared where possible. Every reasonable effort has been made by the publisher (UCLES) to trace copyright holders, but if any items requiring clearance have unwittingly been included, the publisher will be pleased to make amends at the earliest possible opportunity.

Cambridge International Examinations is part of the Cambridge Assessment Group. Cambridge Assessment is the brand name of University of Cambridge Local Examinations Syndicate (UCLES), which is itself a department of the University of Cambridge.